

FRANCE	<b>NOTICE DE POSE</b>		Scannez pour suivre le montage en vidéo ou rendez-vous sur: <a href="http://outsteel.fr/colors">outsteel.fr/colors</a>	Pour toutes questions, remarques, suggestions d'améliorations, contactez notre service consommateurs: <a href="mailto:serviceconsommateurs@poujoulat.fr">serviceconsommateurs@poujoulat.fr</a>	Page 3
UNITED KINGDOM	<b>INSTALLATION INSTRUCTIONS</b>		Scan to follow the assembly in video or go to: <a href="http://outsteel.co.uk">outsteel.co.uk</a>	For any questions, remarks, suggestions for improvement, contact our customer service: <a href="mailto:sales@poujoulat.co.uk">sales@poujoulat.co.uk</a>	Page 3
BELGIQUE	<b>NOTICE DE POSE</b>		Scannez pour suivre le montage en vidéo ou rendez-vous sur: <a href="http://www.outsteel.be/fr/tutos/">www.outsteel.be/fr/tutos/</a>	Pour toutes questions, remarques, suggestions d'améliorations, contactez notre service client: <a href="mailto:info@poujoulat.be">info@poujoulat.be</a>	Page 3
NEDERLAND BELGIË	<b>PLAATSINGS- INSTRUCTIE</b>		Scan om de video te bekijken of ga naar: <a href="http://outsteel.nl">outsteel.nl</a> <a href="http://outsteel.be/nl/instructie-videos/">outsteel.be/nl/instructie-videos/</a>	Voor alle vragen, opmerkingen en verbeteringssuggesties kunt u terecht bij onze klantendienst: <a href="mailto:info@poujoulat.be">info@poujoulat.be</a>	Pagina 11
GERMANY BELGIEN	<b>INSTALLATIONS- ANLEITUNG</b>		Scannen Sie, um die Montage auf Video zu verfolgen, oder besuchen sie: <a href="http://outsteel.de">outsteel.de</a> <a href="http://outsteel.be">outsteel.be</a>	Bei Fragen, Anmerkungen, Verbesserungsvorschlägen wenden Sie sich bitte an unseren Kundenservice: <a href="mailto:zentrale@poujoulat.de">zentrale@poujoulat.de</a> <a href="mailto:info@poujoulat.be">info@poujoulat.be</a>	Seite 11
POLSKA	<b>INSTRUKCJA MONTAŻU</b>		Zeskanuj, aby obejrzeć film lub odwiedź stronę : <a href="http://outsteel.pl">outsteel.pl</a>	W przypadku jakichkolwiek pytań, uwag lub sugestii dotyczących ulepszeń, skontaktuj się z naszym działem obsługi klienta : <a href="mailto:hallo@poujoulat.pl">hallo@poujoulat.pl</a>	Instrukcja montażu online 
ITALIA	<b>ISTRUZIONI PER L'INSTALLAZIONE</b>		Scansiona il codice QR per guardare il video dell'installazione o visitate: <a href="http://poujoulat.it/colors">poujoulat.it/colors</a>	Per qualsiasi domanda, commento, suggerimento per il miglioramento, contatta il nostro servizio clienti : <a href="mailto:export@poujoulat.fr">export@poujoulat.fr</a>	istruzioni di installazione in linea 
ESPAÑA	<b>MANUAL DE INSTALACIÓN</b>		Escanear para ver la instalación en video o visite : <a href="http://poujoulat.es/colors">poujoulat.es/colors</a>	Para cualquier duda, observación o sugerencia de mejora, puede contactar con nuestro servicio de atención al cliente: <a href="mailto:export@poujoulat.fr">export@poujoulat.fr</a>	Manual de instalación en línea 



# NOTICE DE POSE / INSTALLATION INSTRUCTIONS

CS50016 -79270 ST-SYMPHORIEN

## PRODUIT / PRODUCT

Pour un montage au sol / For floor mounting

**COLORS 6 TUILES**  
COLORS 6 TILES

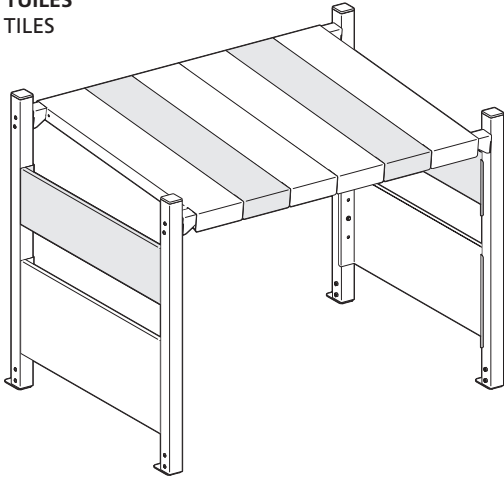

**COLORS 8 TUILES**  
COLORS 8 TILES

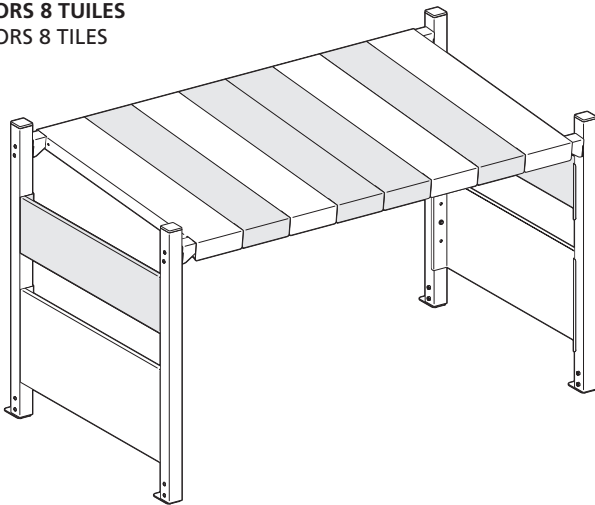

**COLORS 10 TUILES**  
COLORS 10 TILES

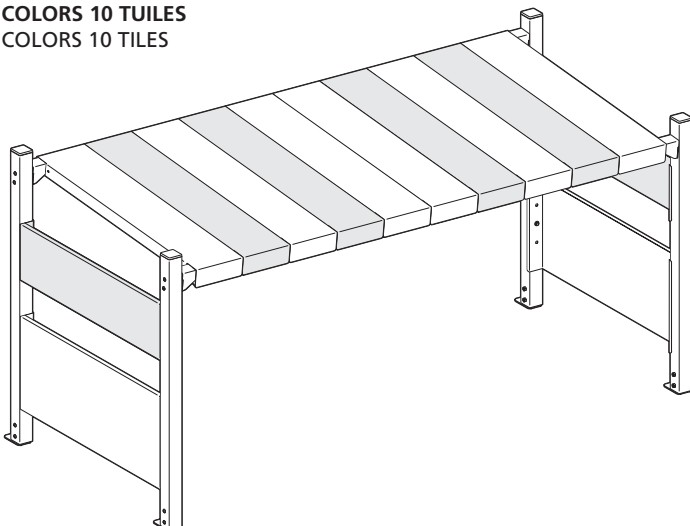

## INFORMATION IMPORTANTE / IMPORTANT INFORMATION

FR

A lire attentivement. Conserver ces informations pour un usage ultérieur.



### AVERTISSEMENT

Malgré les précautions de protection, il peut y avoir un risque de coupure au montage. Pour éviter cela, nous conseillons le port de gants de sécurité EPI (Equipement de Protection Individuelle). Les visseries de fixation ne sont pas incluses car leur choix dépend du matériau du sol sur lequel est fixé le cache. Utilisez des visseries de fixation adaptées au matériau du sol. Visserie de fixation à prévoir M8 ou M6 minimum. Nous vous conseillons des visseries de fixation traitées anti-corrosion. Pour obtenir des conseils sur les fixations à utiliser, adressez-vous à un revendeur spécialisé. Ne pas monter sur le produit. Ne rien poser dessus. Prévoir une surface au sol solide et plane, de dimensions suffisantes(\*) pour accueillir l'habillage de votre équipement.

(\*) voir configurateur - dimensions minimales (largeur et profondeur en mm) variables selon la taille et le modèle retenus.

### Règlementation d'installation d'une pompe à chaleur

L'installation d'une pompe à chaleur ou d'une climatisation doit être réalisée conformément aux recommandations du fabricant et dans le respect des réglementations en vigueur dans le pays d'installation.

GB

Read carefully. Keep this information for future reference.



### WARNING

Despite the protective precautions, there may be a risk of cuts during assembly. To avoid this, we recommend wearing PPE (Personal Protective Equipment) safety gloves. Fixing screws are not included as their choice depends on the material of the floor to which the cover is attached. Use fixing screws suitable for floor in your home. Screwing elements (not provided) : M8 or M6 minimum. We recommend fixing screws treated anti-corrosion. For advice on which fixing devices to use, contact a specialist dealer. Do not climb onto the product. Do not put anything on it. Make sure to have a strong and levelled floor surface, of correct dimensions(\*) for installing the covering on your equipment.

(\*) see configurator - minimum dimensions (width and depth in mm) linked to the size and selected model.

### Installation regulations for a heat pump

The installation of a heat pump or air conditioning should be carried out in accordance with the manufacturer's recommendations and in compliance with local codes and standards.

## OUTILS / TOOLS

Vous munir de / Tools required - not provided :

Clé Allen de 4  
4mm Allen key

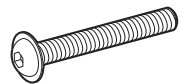



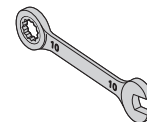



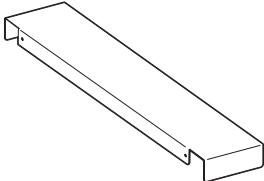

Clé mixte de 10  
10mm combination wrench

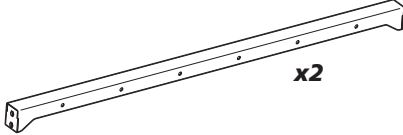

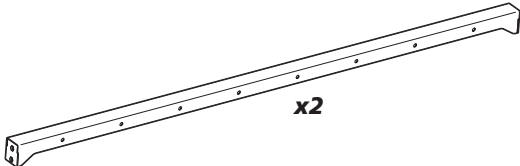
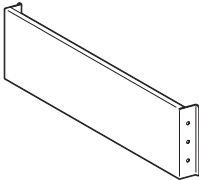
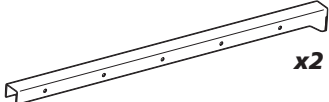
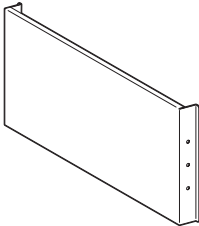
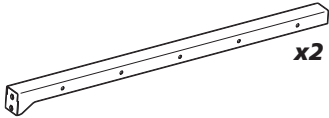

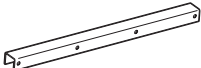
**COMPOSANTS DU PRODUIT / PRODUCT COMPONENTS**

COMPOSANTS / COMPONENTS

<p><b>Tuiles</b> Tiles</p> <p><b>(A)</b></p>		<p><b>x2</b></p>	<p><b>Montants arrière</b> Rear uprights</p> <p><b>(E)</b></p>		<p><b>x2</b></p>
<p><b>Barres support modèle 6 tuiles</b> Support bars 6 tiles model</p> <p><b>(B1)</b></p>		<p><b>x2</b></p>	<p><b>Pieds</b> Feet</p> <p><b>(F)</b></p>		<p><b>x4</b></p>
<p><b>Barres support modèle 8 tuiles</b> Support bars 8 tiles model</p> <p><b>(B2)</b></p>		<p><b>x2</b></p>	<p><b>Petites faces latérales hautes</b> Small faces top side</p> <p><b>(G)</b></p>		<p><b>x2</b></p>
<p><b>Barres support gauche modèle 10 tuiles</b> Left support bars 10 tiles model</p> <p><b>(B3)</b></p>		<p><b>x2</b></p>	<p><b>Grandes faces latérales basses</b> Large faces bottom side</p> <p><b>(H)</b></p>		<p><b>x2</b></p>
<p><b>Barres support droite modèle 10 tuiles</b> Right support bars 10 tiles model</p> <p><b>(B4)</b></p>		<p><b>x2</b></p>	<p><b>Capuchon</b> Cap</p> <p><b>(I)</b></p>		<p><b>x4</b></p>
<p><b>Eclisses pour modèle 10 tuiles</b> Splices for 10 tiles model</p> <p><b>(C)</b></p>		<p><b>x2</b></p>	<p><b>Montants avant</b> Front uprights</p> <p><b>(D)</b></p>		<p><b>x2</b></p>

VISSERIE / SCREWS

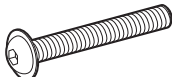
	Modèle 6 tuiles 6 tiles model	Modèle 8 tuiles 8 tiles model	Modèle 10 tuiles 10 tiles model	
<p><b>Ecrou M6</b> Nut M6</p> <p><b>(J)</b></p>		<p><b>x20</b></p>	<p><b>x24</b></p>	<p><b>x28</b></p>
<p><b>Rondelle</b> Washer</p> <p><b>(K)</b></p>		<p><b>x28</b></p>	<p><b>x32</b></p>	<p><b>x36</b></p>
<p><b>Vis H M6x16</b> Screws H M6x16</p> <p><b>(L)</b></p>		<p><b>x20</b></p>	<p><b>x24</b></p>	<p><b>x28</b></p>
<p><b>Vis TBCE M6x50</b> Screws TBCE M6x50</p> <p><b>(M)</b></p>		<p><b>x16</b></p>	<p><b>x16</b></p>	<p><b>x16</b></p>

**POSE DU PRODUIT / PRODUCT INSTALLATION**

- 1 - Installer et fixer les barres support sur les tuiles (Protéger les tuiles en mettant une couverture au sol)**  
 Install and fix the support bars on the tiles (Protect the tiles by putting a cover on the ground)

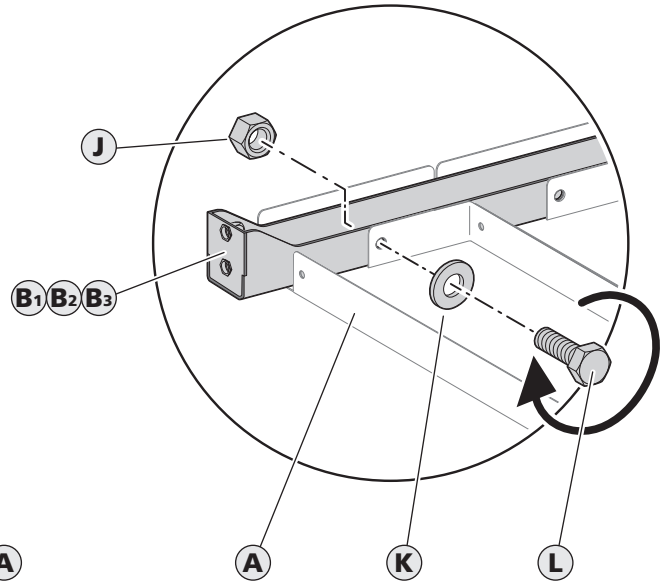
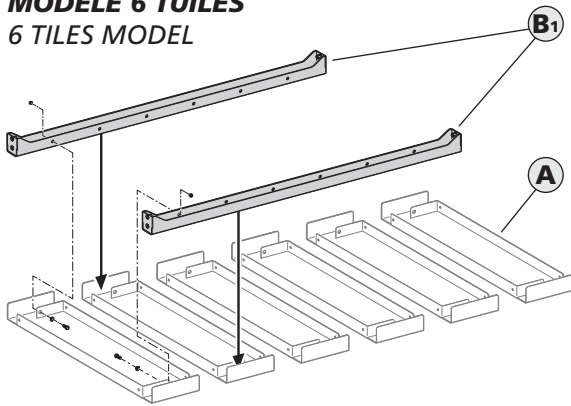
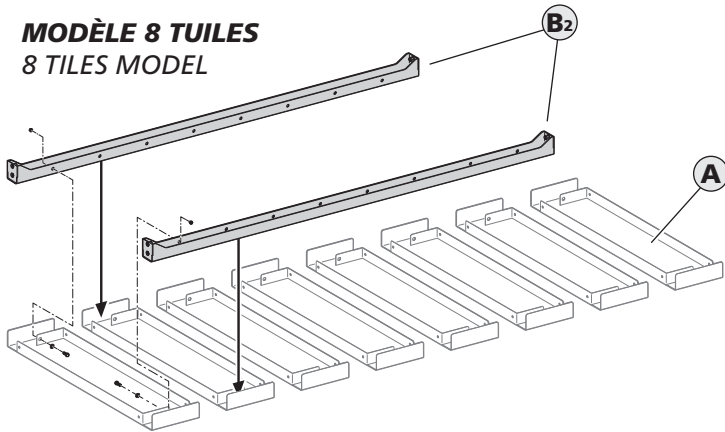
**MODÈLE 6 TUILES****6 TILES MODEL****MODÈLE 8 TUILES****8 TILES MODEL****MODÈLE 10 TUILES / 10 TILES MODEL**

- Pour les modèles 10 tuiles, une éclisse est nécessaire pour rigidifier et relier les barres supports (à placer à l'intérieur des barres supports)**  
 For the 10 tiles models, a splice is necessary to stiffen and connect the support bars (to be placed inside the support bars)

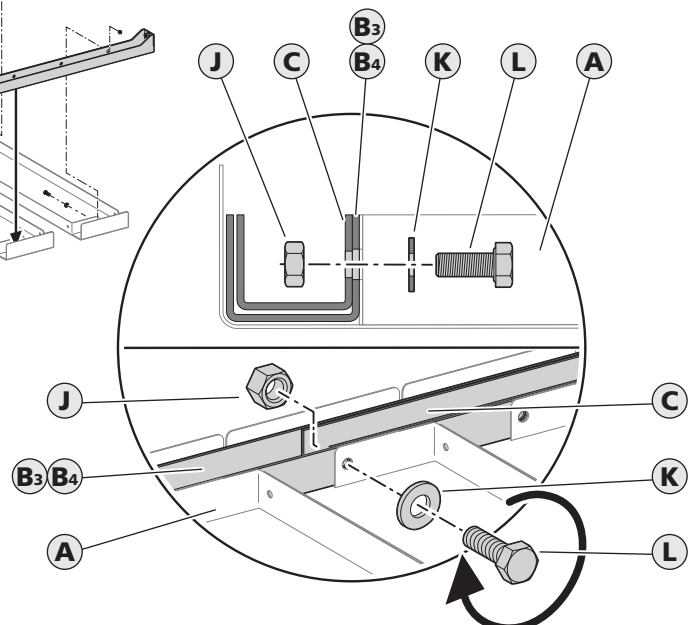
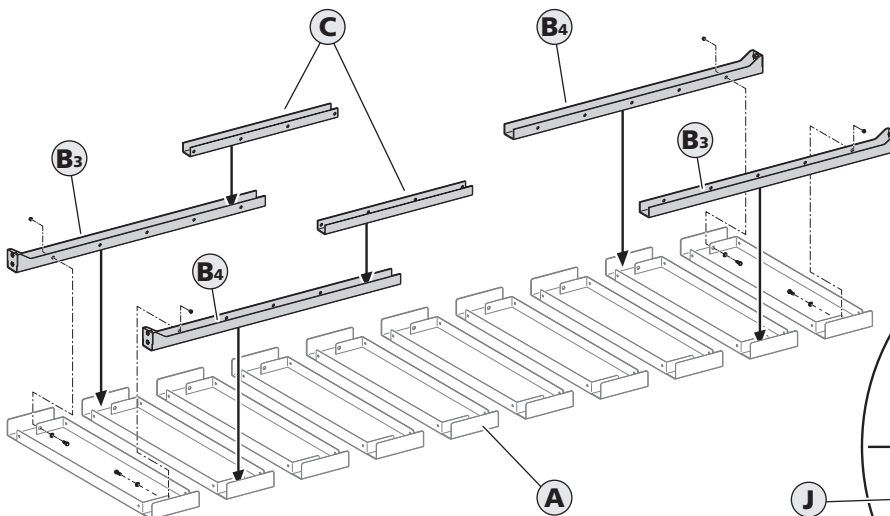

**- 2 - Installer et fixer les pieds**  
Install and fix the feet

**MODÈLE 6, 8 ET 10 TUILES / 6, 8 AND 10 TILES MODEL**

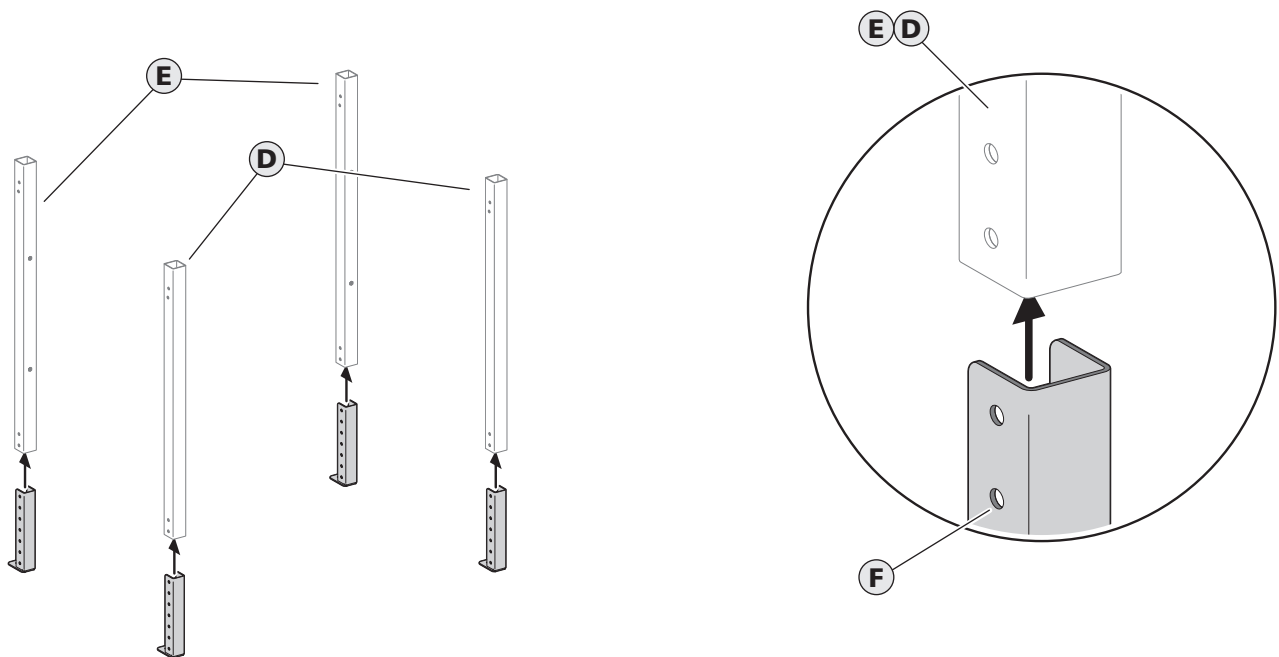

**RÉGLAGES DES PIEDS / FEET ADJUSTMENTS**

Régler les pieds pour adapter le cache à votre unité. La hauteur utile  $H_u$  est réglable de 660 mm minimum à 810 mm maximum.  
Adjust the feet to adapt OUTSTEEL to your unit. The interior height  $H_u$  can be adjusted from 660 to 810 mm.

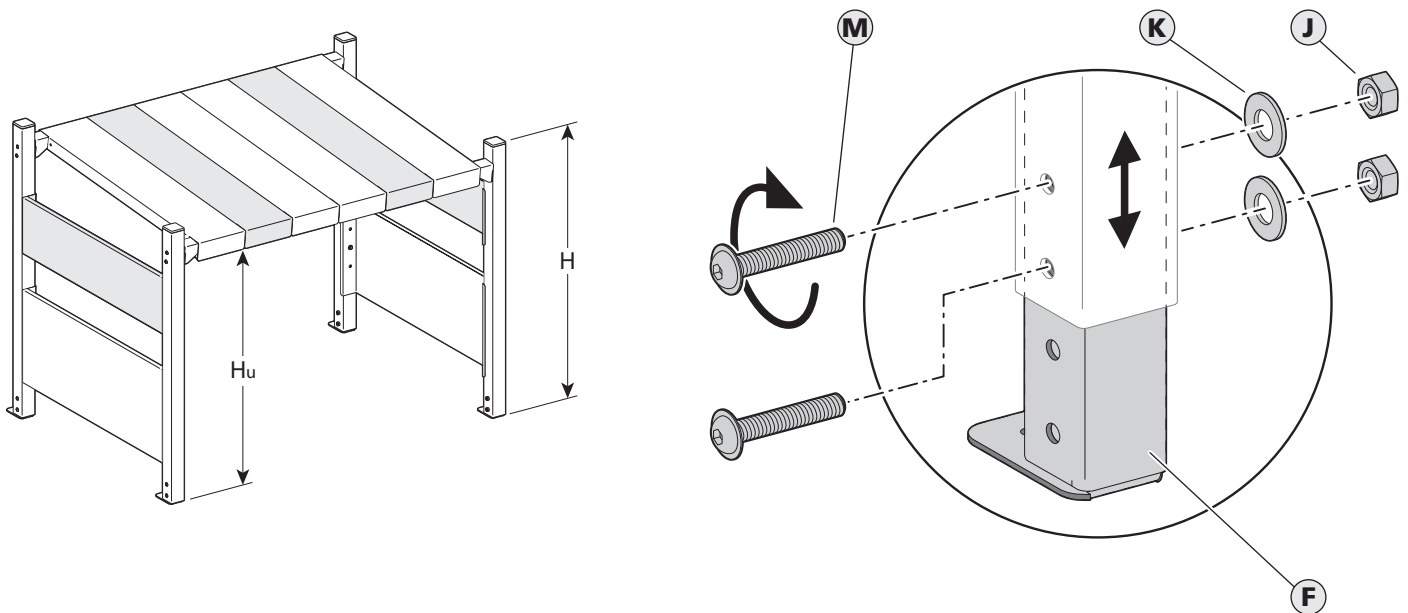

**- 3 - Installer et fixer les faces latérales**  
Install and fix the side faces

**MODÈLE 6, 8 ET 10 TUILES / 6, 8 AND 10 TILES MODEL**

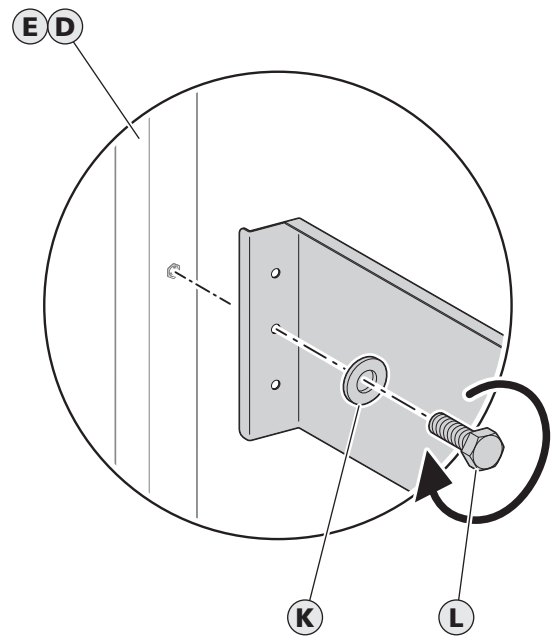
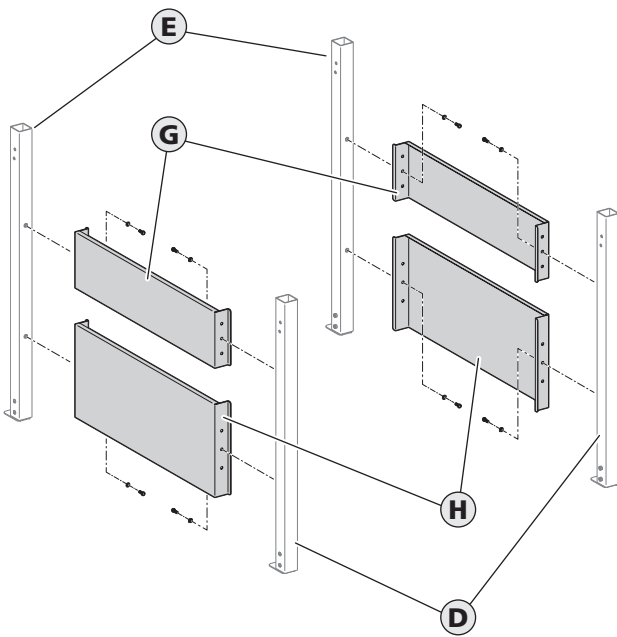

**- 4 - Insérer les capuchons**  
Insert the caps

**MODÈLE 6, 8 ET 10 TUILES / 6, 8 AND 10 TILES MODEL**

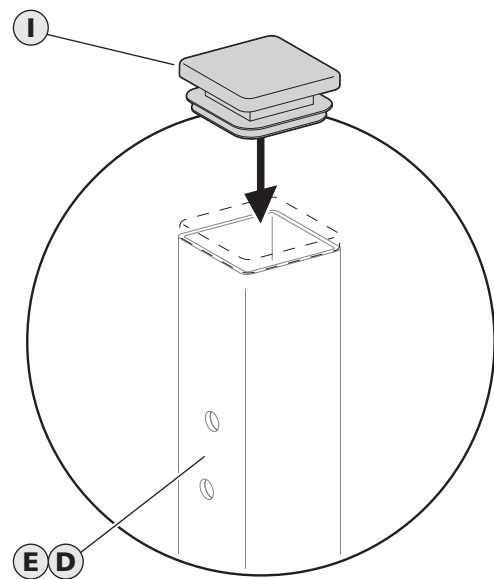
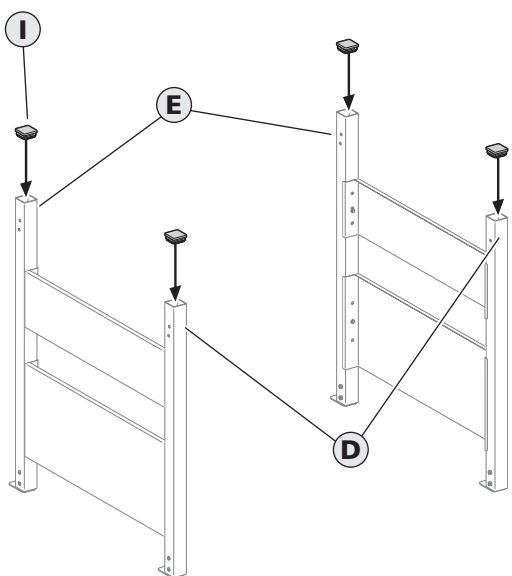

- 5 - Assembler et fixer les barres support aux montants  
Assemble and fix the support bars to the uprights

**MODÈLE 6 TUILES / 6 TILES MODEL**

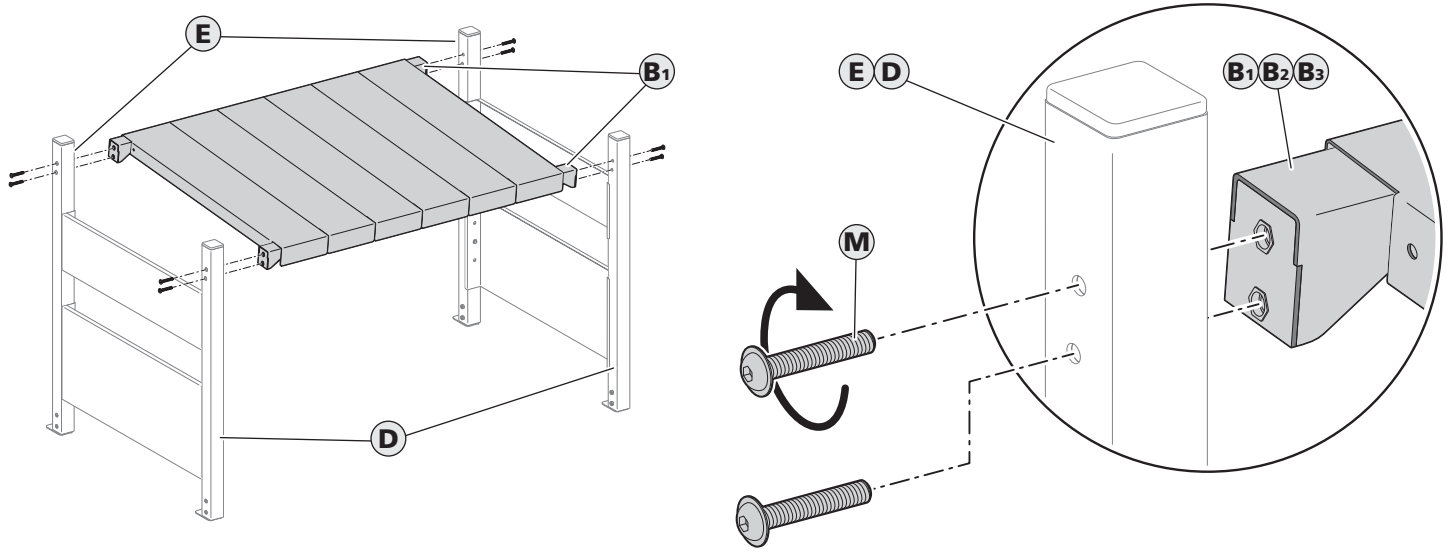

**MODÈLE 8 TUILES / 8 TILES MODEL**

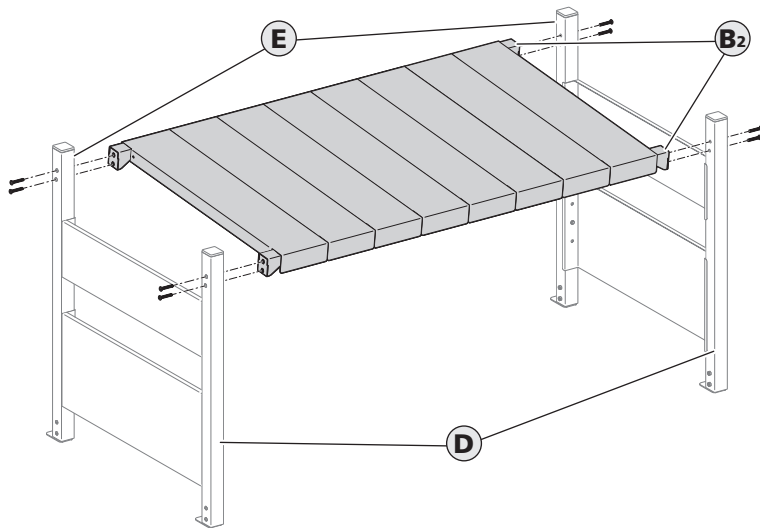

**MODÈLE 10 TUILES / 10 TILES MODEL**

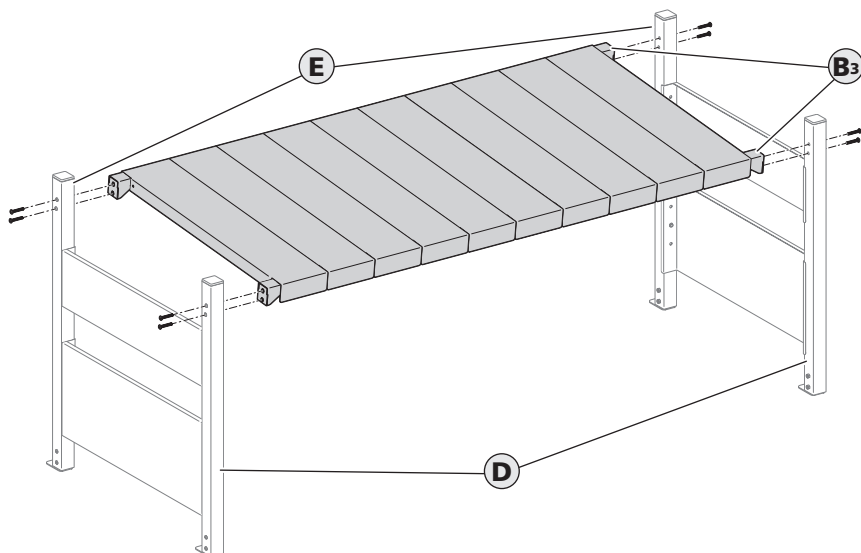



**FIXATION AU SOL RECOMMANDÉE ! / FLOOR FIXING RECOMMENDED!**

Utilisez des visseries de fixation adaptées au matériau du sol. Visserie de fixation à prévoir M8 ou M6 minimum.

Nous vous conseillons des visseries de fixation traitées anti-corrosion

Use fixing screws suitable for floor in your home. Screwing elements (not provided) : M8 or M6 minimum.

We would recommend you using fixings protected against corrosion.

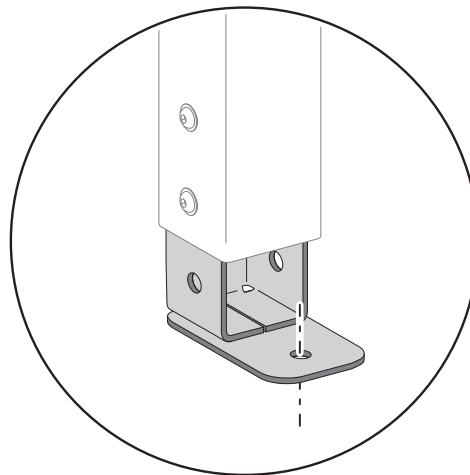
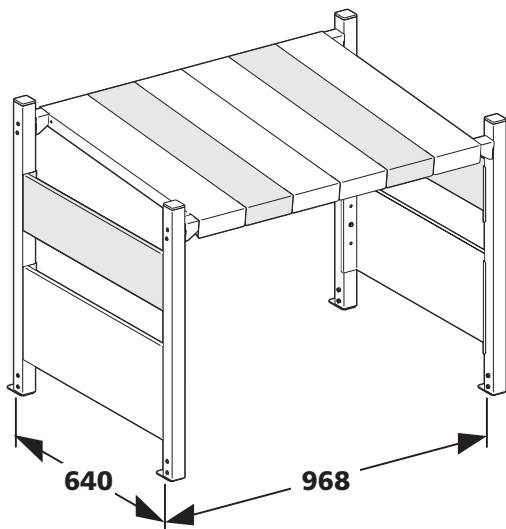
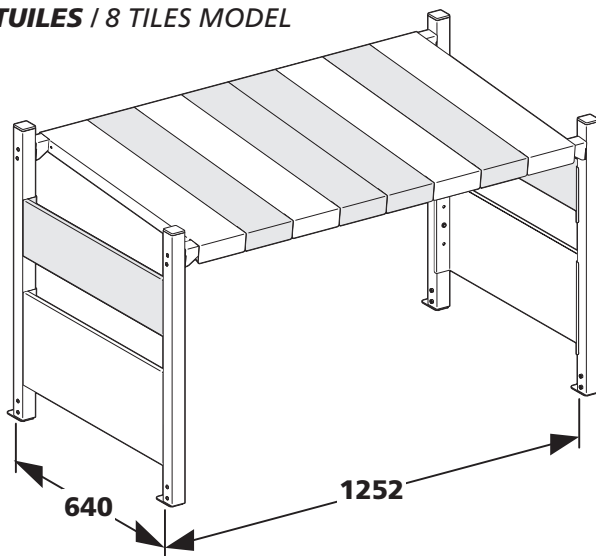
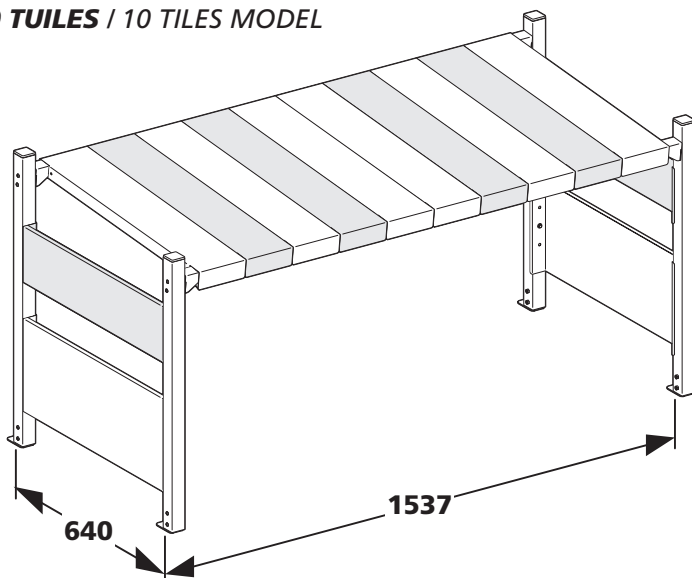
**MODÈLE 6 TUILES / 6 TILES MODEL****MODÈLE 8 TUILES / 8 TILES MODEL****MODÈLE 10 TUILES / 10 TILES MODEL**

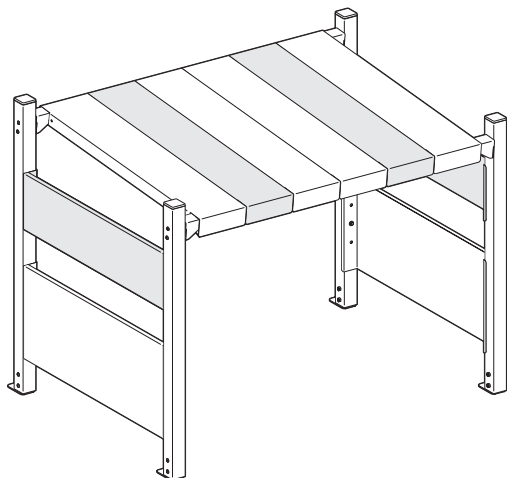
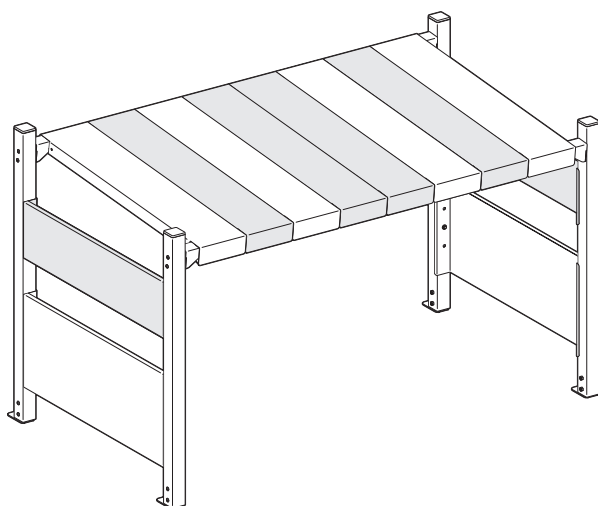
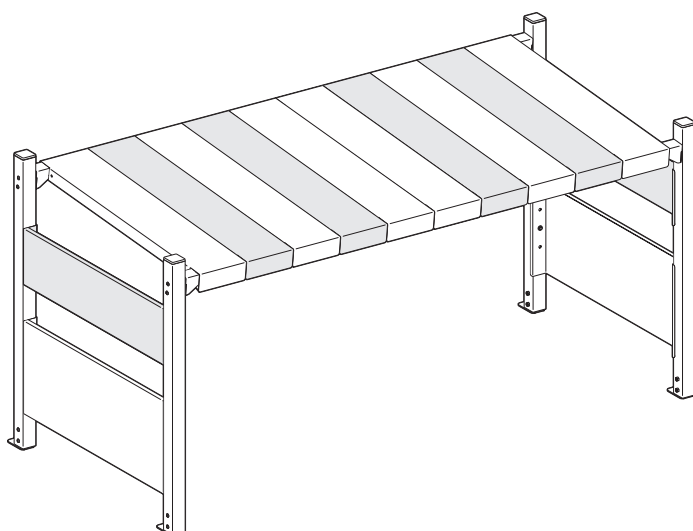
**FIN DE MONTAGE / INSTALLATION COMPLETE****MODÈLE 6 TUILES / 6 TILES MODEL****MODÈLE 8 TUILES / 8 TILES MODEL****MODÈLE 10 TUILES / 10 TILES MODEL**

# PLAATSINGSINSTRUCTIE / INSTALLATIONSANLEITUNG

CS50016 -79270 ST-SYMPHORIEN

## PRODUCT / PRODUKT

Voor vloermontage / Für Bodenmontage

COLORS 6-DELIG  
COLORS 6 KACHELN

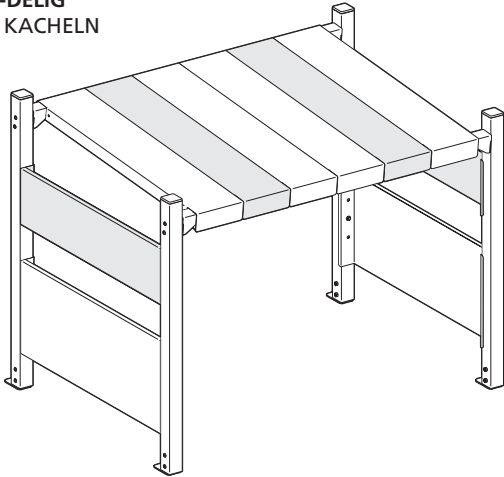

COLORS 8-DELIG  
COLORS 8 KACHELN

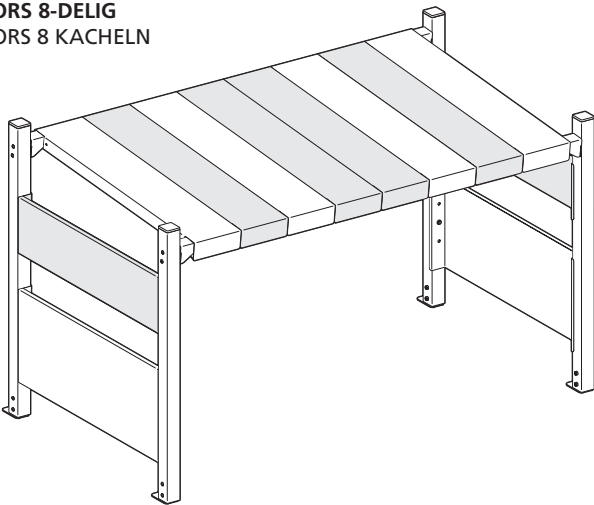

COLORS 10-DELIG  
COLORS 10 KACHELN

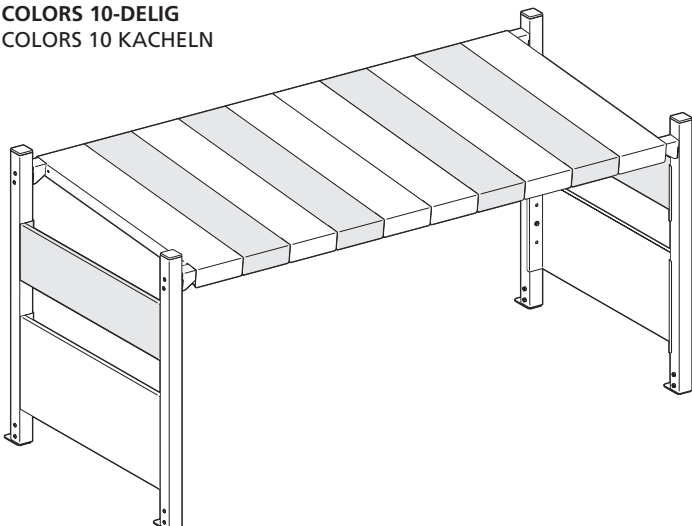

## BELANGRIJKE INFORMATIE / WICHTIGE INFORMATIONEN

NL

Aandachtig doornemen. Bewaar deze informatie voor een later gebruik.



### WAARSCHUWING

Ondanks de beschermende voorzorgsmaatregelen kan er gevaar zijn op snijwonden bij montage. Om dit te voorkomen, raden wij aan veiligheidshandschoenen van het type PBM (persoonlijke beschermingsmiddelen) te dragen. De bevestigingsmiddelen zijn niet bij de levering inbegrepen, aangezien de keuze daarvan afhankelijk is van het gebruikte materiaal in de muur waaraan de omkasting wordt bevestigd. Gebruik aangepaste bevestigingsmiddelen in functie van het gebruikte materiaal voor de muur en de vloer. Te voorziene bevestigingsmiddelen: M6. Wij bevelen het gebruik aan van bevestigingsmiddelen die zijn behandeld tegen corrosie. Zorg voor een stevige, vlakke vloer die groot genoeg is<sup>(\*)</sup> voor de bekleding van uw apparatuur. Neem voor advies over de te gebruiken bevestigingsmiddelen contact op met een gespecialiseerde verkoper. Wij raden aan dat er 2 personen beschikbaar worden gehouden voor de muur-montage. Klim niet op het product. Plaats niets op de omkasting.

(\* ) zie configurator - de minimumafmetingen (breedte en diepte in mm) verschillen in functie van de grootte en het gekozen model.

### Installatievoorschriften voor een warmtepomp

De installatie van een warmtepomp of een airco moet worden uitgevoerd volgens de aanbevelingen van de fabrikant en in conformiteit met de geldende regelgeving in het land van installatie.

DE

Bitte lesen Sie diese Anleitung aufmerksam durch. Bewahren Sie diese Informationen für den späteren Gebrauch auf.



### WARNUNG

Trotz der Schutzvorkehrungen kann es bei der Montage zu Schnittgefahr kommen. Um dies zu vermeiden, empfehlen wir das Tragen von PSA-Schutzhandschuhen (Persönliche Schutzausrüstung). Befestigungen sind nicht enthalten, da ihre Wahl vom Material der Wand abhängt, an der die Abdeckung befestigt wird. Verwenden Sie Befestigungsmittel, die für das Wand- und Bodenmaterial geeignet sind. Erforderliche Befestigungsschrauben: M6. Wir empfehlen korrosionsgeschützte Befestigungsschrauben. Sorgen Sie für eine feste und ebene Bodenfläche von ausreichender Größe(\*), um das Gehäuse Ihres Geräts aufzunehmen. Wenden Sie sich für eine Beratung zu den zu verwendenden Befestigungen an einen Fachhändler. Für die Montage empfehlen wir die Anwesenheit von 2 Personen. Klettern Sie nicht auf das Produkt. Modell für eine maximale Belastung von 15 kg ausgelegt.

(\* ) siehe Konfigurator - Mindestabmessungen (Breite und Tiefe in mm) variieren je nach gewählter Größe und Modell.

### Vorschriften für die Installation einer Wärmepumpe

Die Installation einer Wärmepumpe oder Klimaanlage muss gemäß den Empfehlungen des Herstellers und unter Einhaltung der im Installationsland geltenden Vorschriften erfolgen.

## GEREEDSCHAP / WERKZEUGE

Zorg voor het volgende gereedschap / Halten Sie Folgendes bereit:

Inbussleutel 4  
Inbusschlüssel Größe 4

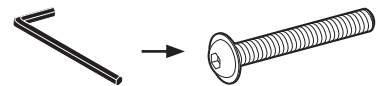



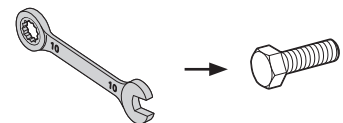



Combisleutel 10  
Ringmaulschlüssel 10

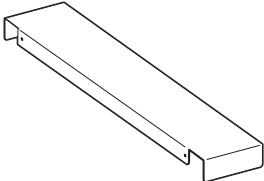

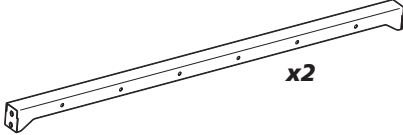

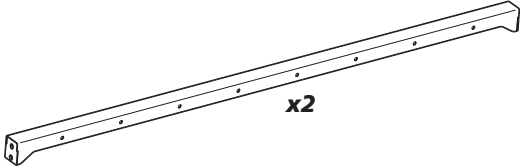
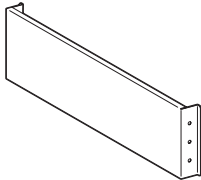
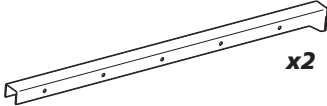
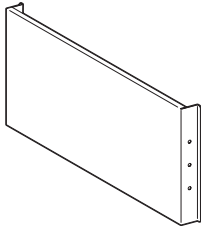
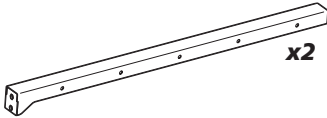
**ONDERDELEN VAN HET PRODUCT / PRODUKTKOMPONENTEN**

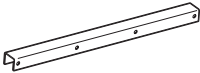
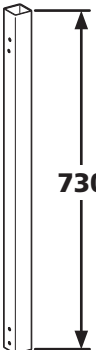
**ONDERDELEN / KOMPONENTEN**

<p><b>Platen</b> (A) Kacheln</p>		<p><b>x2</b></p>	<p><b>Stijlen achter</b> (E) Hintere Stützen</p>		<p><b>x2</b></p>
<p><b>Steunstangen</b> (B1) model met 6 platen Stützstangen Modell 6 Kacheln</p>		<p><b>x2</b></p>	<p><b>Pootjes</b> (F) Beine</p>		<p><b>x4</b></p>
<p><b>Steunstangen</b> (B2) model met 8 platen Stützstangen Modell 8 Kacheln</p>		<p><b>x2</b></p>	<p><b>Kleine zijden</b> (G) Zijpanelen hoog Kleine Seitenwände hohe Seiten</p>		<p><b>x2</b></p>
<p><b>Steunstangen links</b> (B3) model met 10 platen Stützstangen links Modell 10 Kacheln</p>		<p><b>x2</b></p>	<p><b>Grote zijden</b> (H) Zijpanelen laag Große Seitenflächen niedrige Seitenwände</p>		<p><b>x2</b></p>
<p><b>Steunstangen rechts</b> (B4) model met 10 platen Stützstangen rechts Modell 10 Kacheln</p>		<p><b>x2</b></p>	<p><b>Kap</b> (I) Kappe</p>		<p><b>x4</b></p>
<p><b>Tussenstukken</b> (C) voor model met 10 platen Laschen für Modell 10 Kacheln</p>		<p><b>x2</b></p>	<p><b>Stijlen voor</b> (D) Vorderer Pfosten</p>		<p><b>x2</b></p>

**SCHROEVEN / SCHRAUBEN**

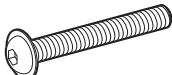
		Model met 6 platen Modell 6 Kacheln	Model met 8 platen Modell 8 Kacheln	Model met 10 platen Modell 10 Kacheln
<p><b>Bout M6</b> (J) Mutter M6</p>		<p><b>x20</b></p>	<p><b>x24</b></p>	<p><b>x28</b></p>
<p><b>Drukring</b> (K) Unterlegscheibe</p>		<p><b>x28</b></p>	<p><b>x32</b></p>	<p><b>x36</b></p>
<p><b>H schroef M6x16</b> (L) H-Schraube M6x16</p>		<p><b>x20</b></p>	<p><b>x24</b></p>	<p><b>x28</b></p>
<p><b>TBCE schroef 6x50</b> (M) TBCE-Schraube M6x50</p>		<p><b>x16</b></p>	<p><b>x16</b></p>	<p><b>x16</b></p>

**PLAATSING VAN HET PRODUCT / ANBRINGEN DES PRODUKTS****- 1 - Plaats en bevestig de steunstangen op de platen (bescherm de platen door een deken op de vloer te leggen)**

Installieren und befestigen Sie die Stützstangen an den Kacheln (Schützen Sie die Kacheln, indem Sie eine Abdeckung auf den Boden legen)

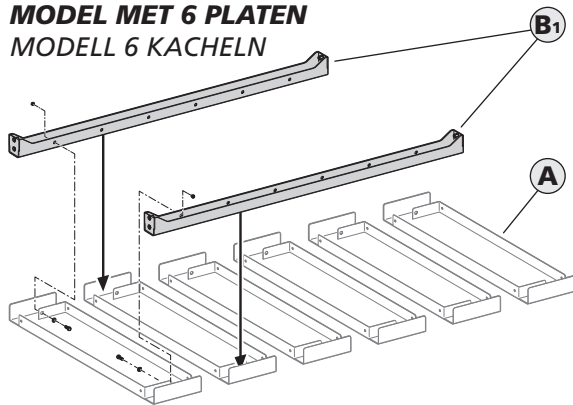
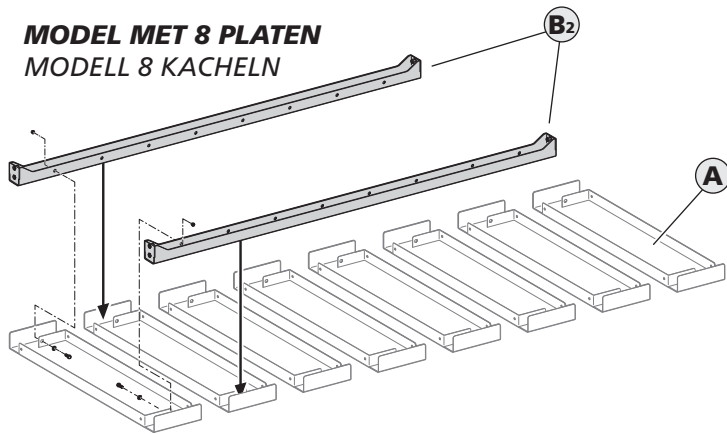
**MODEL MET 6 PLATEN****MODELL 6 KACHELN****MODEL MET 8 PLATEN****MODELL 8 KACHELN****MODEL MET 10 PLATEN / MODELL 10 KACHELN**

Voor modellen met 10 platen is een tussenstuk nodig om de steunstangen steviger te maken en onderling te verbinden (te plaatsen aan de binnenkant van de steunstangen)

Bei Modellen mit 10 Kacheln ist eine Lasche erforderlich, um die Stützstangen zu versteifen und zu verbinden (wird innerhalb der Tragstäbe angebracht)

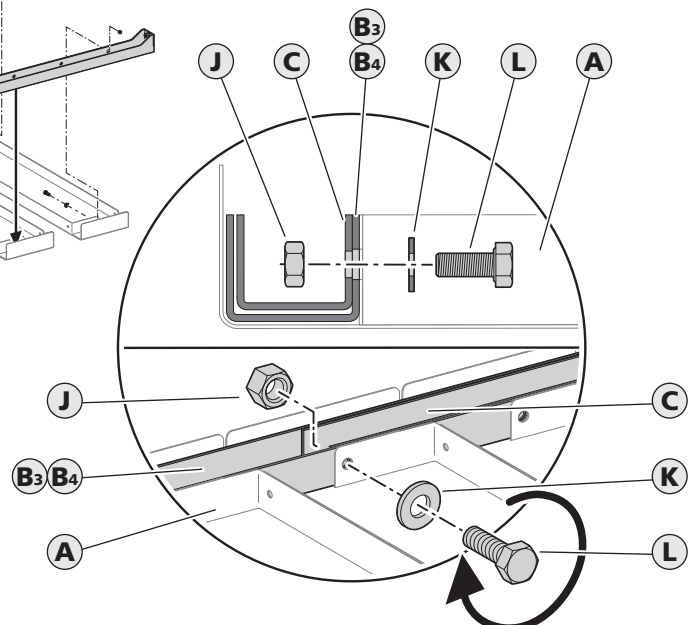
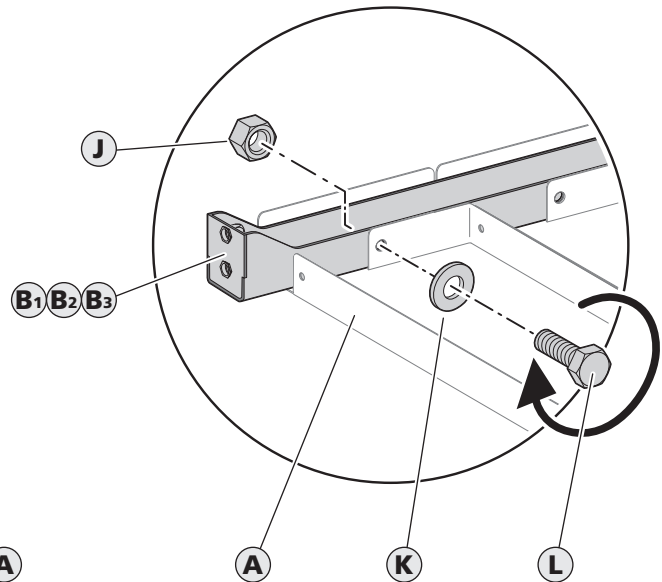
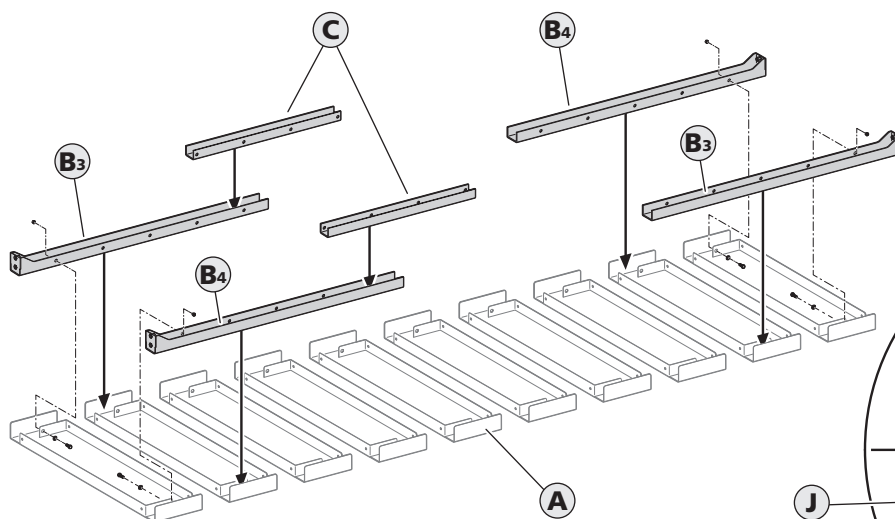

**- 2 - Monteer en bevestig de pootjes**

Installieren und befestigen Sie die FüÙe

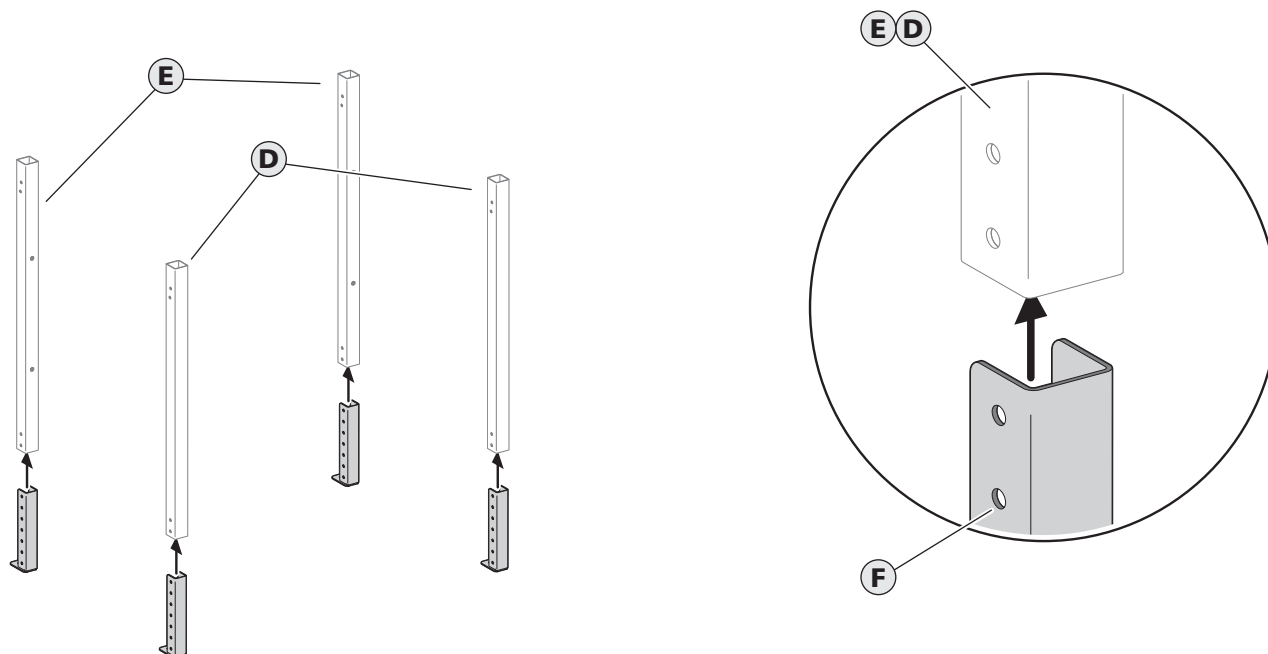
**MODEL 6, 8 EN 10 PLATEN / MODELL 6, 8 UND 10 KACHELN****AFSTELLEN VAN DE POOTJES / FUSSEINSTELLUNGEN**

Pas de pootjes aan om de omkasting aan te passen aan uw eenheid. De nuttige hoogte  $H_u$  kan worden ingesteld van minimaal 660 mm tot maximaal 810 mm.

Stellen Sie die FüÙe ein, um die Blende an Ihre Einheit anzupassen. Die Nutzhöhe  $H_u$  ist von mindestens 660 mm bis maximal 810 mm einstellbar.

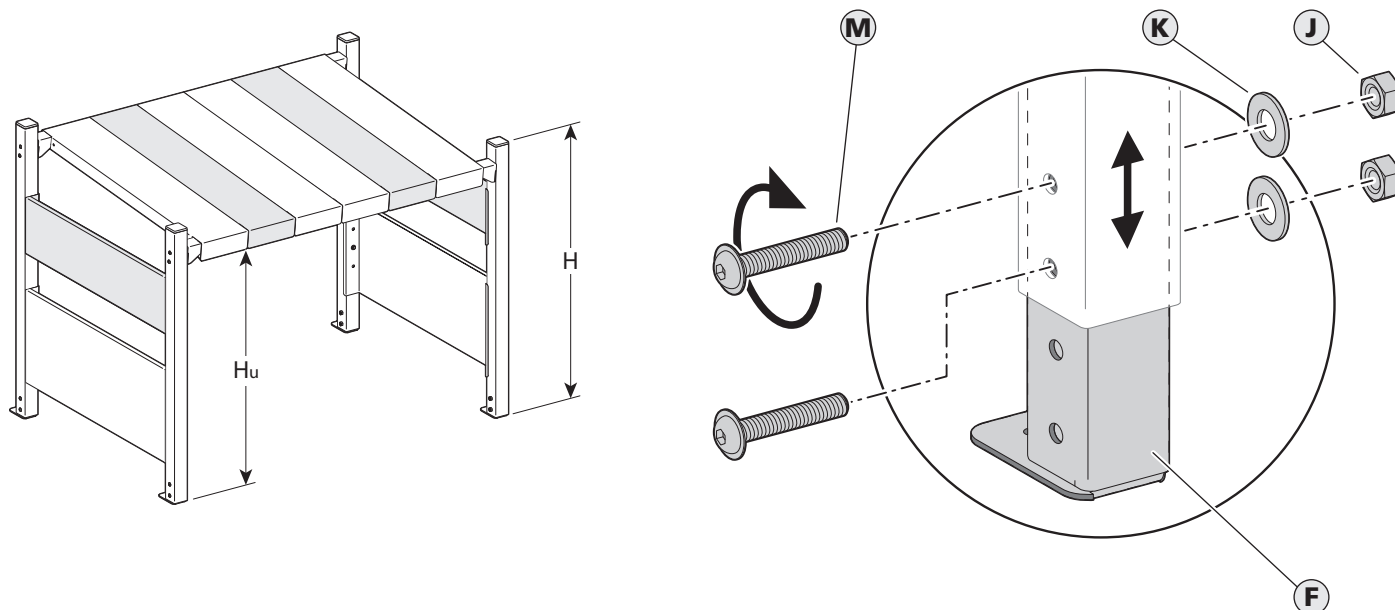

- 3 - Installeer en bevestig de zijpanelen**  
 Installieren und befestigen Sie die Seitenflächen

**MODEL 6, 8 EN 10 PLATEN / MODELL 6, 8 UND 10 KACHELN**

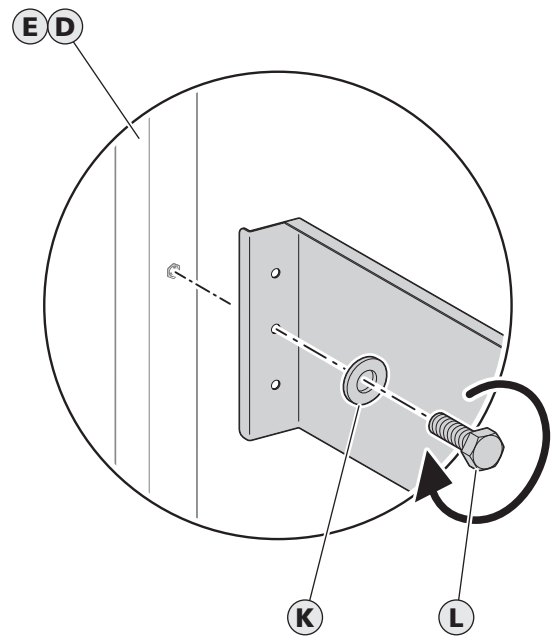
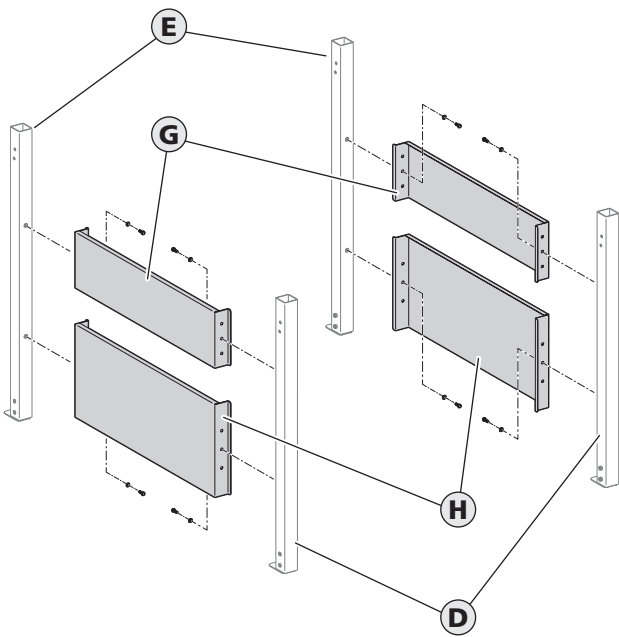

- 4 - Plaats de kappen**  
 Kappen einsetzen

**MODEL 6, 8 EN 10 PLATEN / MODELL 6, 8 UND 10 KACHELN**

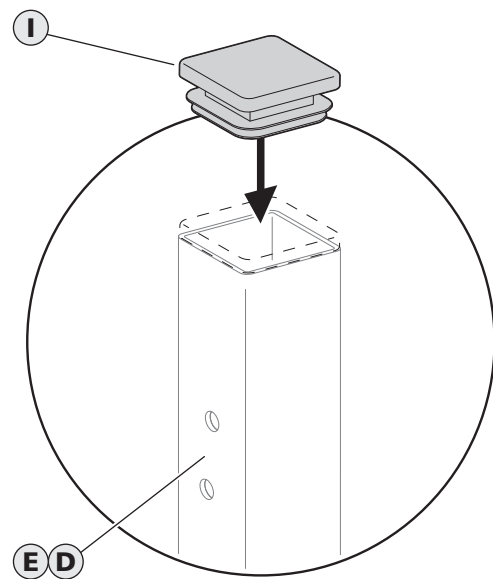
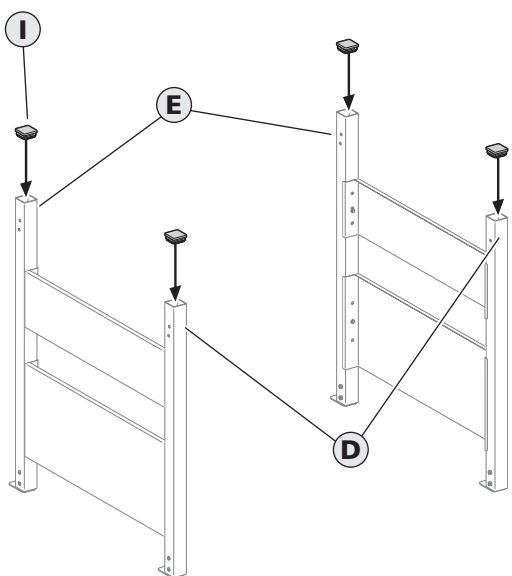

- 5 - Monteer en bevestig de steunstangen aan de pijlers  
Zusammensetzen und Befestigen der Stützstangen an den Pfosten

**MODEL MET 6 PLATEN / MODELL 6 KACHELN**

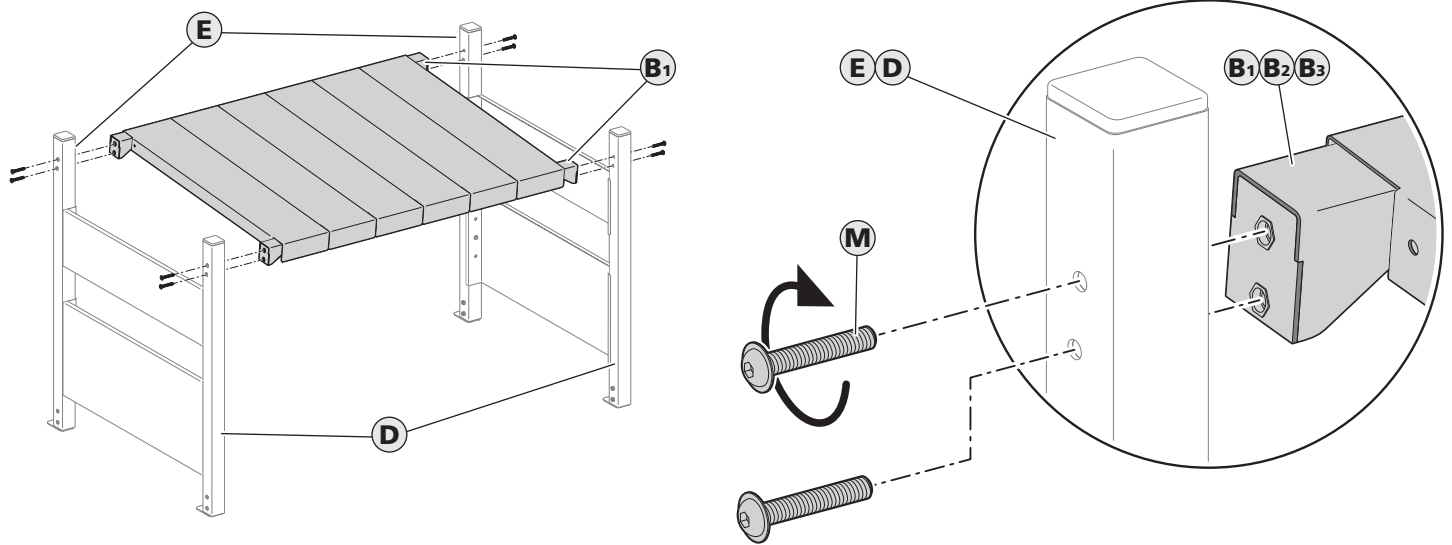

**MODEL MET 8 PLATEN / MODELL 8 KACHELN**

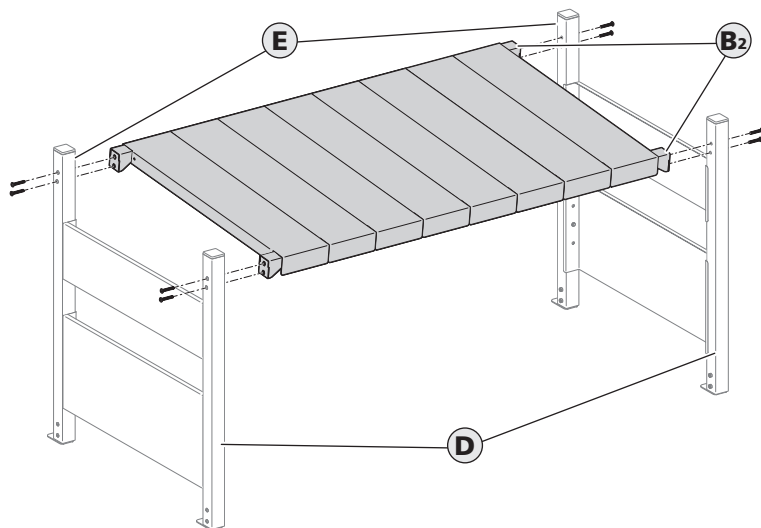

**MODEL MET 10 PLATEN / MODELL 10 KACHELN**

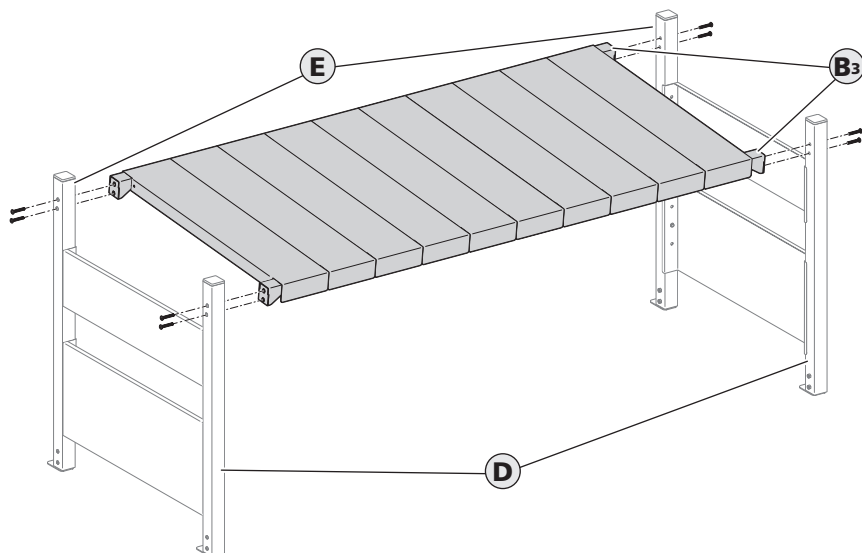



**VLOERBEVESTIGING AANBEVOLEN! / BODENBEVESTIGUNG WIRD EMPFOHLEN!**

Gebruik bevestigingsmiddelen die zijn aangepast aan het materiaal van de vloer. Te voorziene bevestigingsmiddelen: minimaal M8 of M6. Wij bevelen het gebruik aan van bevestigingsmiddelen die zijn behandeld tegen corrosie. Verwenden Sie Befestigungsschrauben, die für das Material des Bodens geeignet sind. Die Befestigungsschrauben sollten mindestens M8 oder M6 betragen. Wir empfehlen korrosionsgeschützte Befestigungsschrauben.

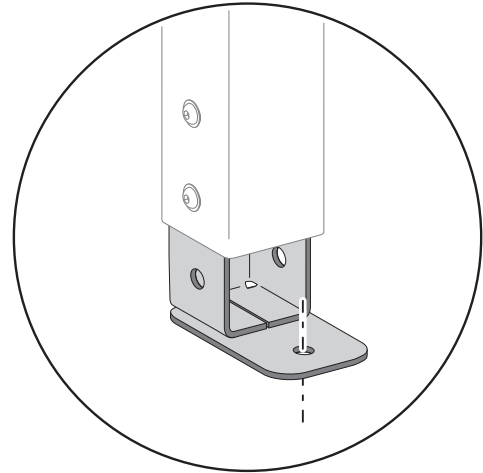
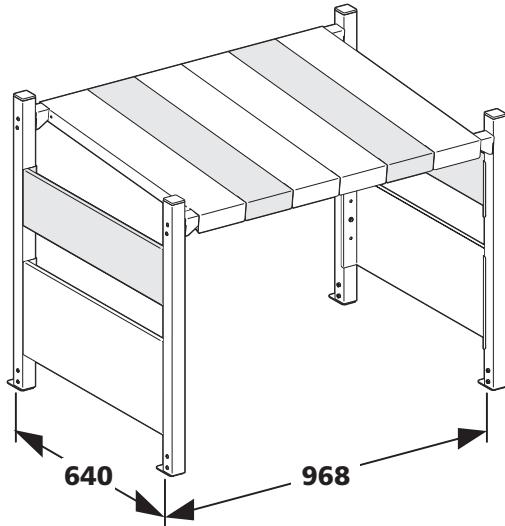
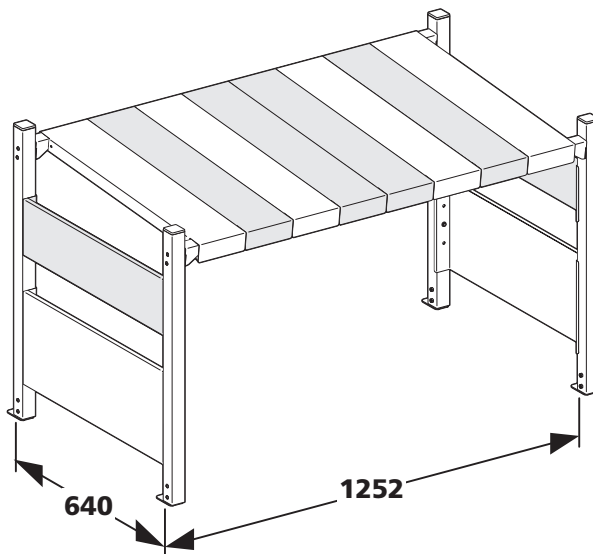
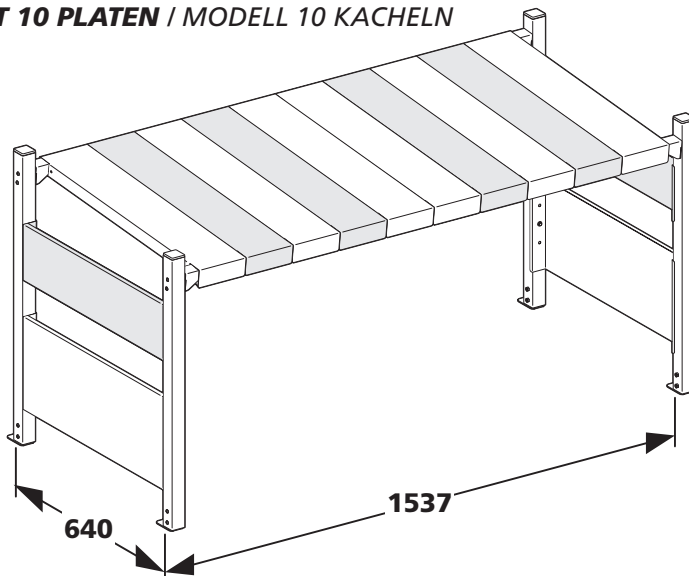
**MODEL MET 6 PLATEN / MODELL 6 KACHELN****MODEL MET 8 PLATEN / MODELL 8 KACHELN****MODEL MET 10 PLATEN / MODELL 10 KACHELN**

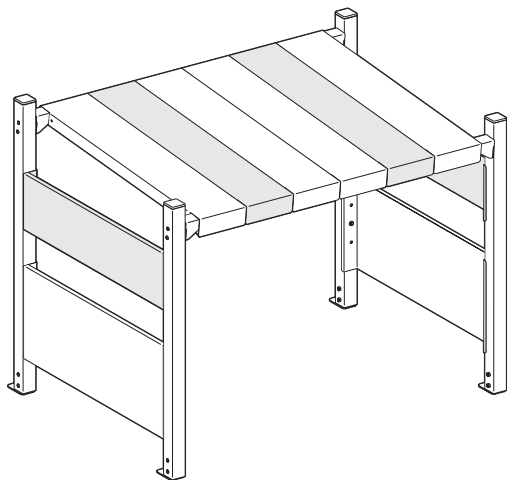
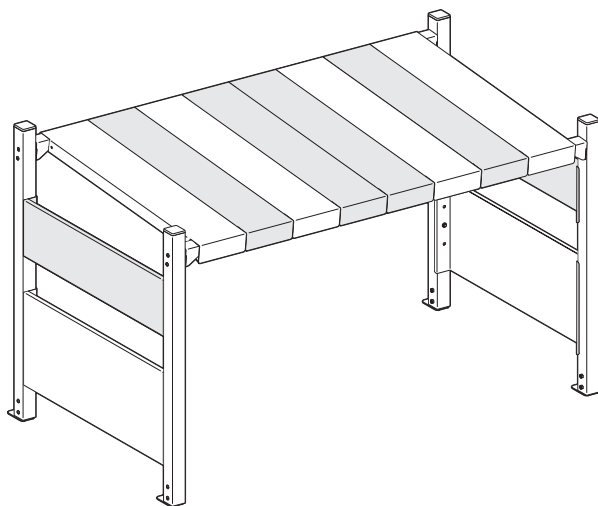
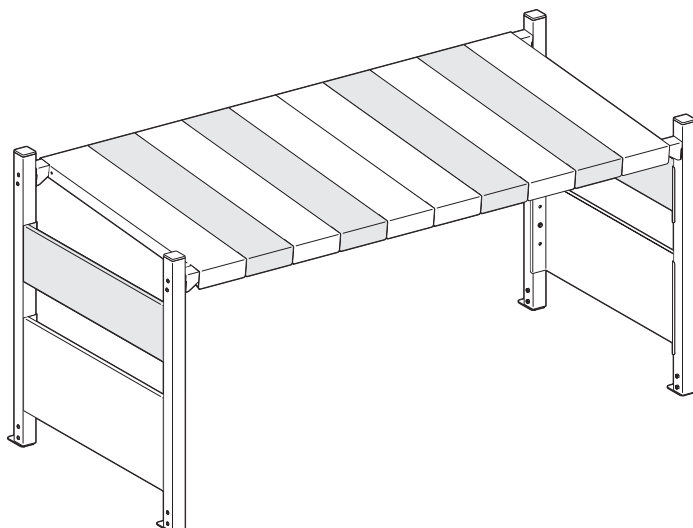
**EINDE MONTAGE / MONTAGEENDE****MODEL MET 6 PLATEN / MODELL 6 KACHELN****MODEL MET 8 PLATEN / MODELL 8 KACHELN****MODEL MET 10 PLATEN / MODELL 10 KACHELN**



**FRANCE**

POUJOLAT SA  
CS50016  
79270 ST-SYMPHORIEN  
Tél. +33 (0) 5 49 04 40 40  
serviceconsommateurs@poujolat.fr  
www.poujolat.fr

**UNITED KINGDOM**

POUJOLAT (UK) LTD  
Unit 1a Quadrum Park  
Old Portsmouth Road  
GU3 1LU Guilford / SURREY  
Tel. +44 (0) 1483 461 700  
sales@poujolat.co.uk  
www.poujolat.co.uk

**BELGIQUE / BELGIE**

POUJOLAT BELUX  
Rue de l'Industrie, 39  
B-1400 NIVELLES  
Tel. +32 (0) 67 / 84 02 02  
info@poujolat.be  
www.poujolat.be

**NEDERLAND**

POUJOLAT BV  
Ettensestr 60  
7061 AC TERBORG  
Tel. +31 (0) 315 340050  
info@poujolat.be  
info@poujolat.nl  
www.poujolat.nl

**DEUTSCHLAND**

POUJOLAT GMBH  
Johann-Philipp Reis Strasse 6  
55469 SIMMERN  
Tel. +49 676194140  
zentrale@poujolat.de  
info@poujolat.de  
www.poujolat.de

**POLSKA**

POUJOLAT SP. Z O.O.  
Ul. Olszankowa 45  
05 -120 Legionowo  
Tel. +48 889 555 999  
hallo@poujolat.pl  
www.poujolat.pl

**ITALIA**

POUJOLAT SA  
CS50016  
79270 ST-SYMPHORIEN  
export@poujolat.fr  
www.poujolat.it

**ESPAÑA**

POUJOLAT SA  
CS50016  
79270 ST-SYMPHORIEN  
export@poujolat.fr  
www.poujolat.es

